

---

# Installation Guide

Publication Number E8018-97000

First Edition, December 1998

For Safety Information, Warranties, and Regulatory Information, see the pages at the end of this manual.

© Copyright Hewlett-Packard Company 1994-1998

All Rights Reserved.

---

## HP E8018A Analysis Probe for HITACHI SH7708/18

---

# The HP E8018A Analysis Probe —At a Glance

The HP E8018A Analysis Probe provides a complete interface for state or timing analysis between any SH7708 or SH7708 target system and the following HP logic analyzers:

- HP 16600A
- HP 16601A
- HP 16602A
- HP 16550A (one or two cards)
- HP 16555A/D (two or three cards)
- HP 16556A/D (two or three cards)
- HP 16557D (two or three cards)

The Analysis Probe provides the physical connection between the target microprocessor and the logic analyzer. The configuration software sets up the logic analyzer for compatibility with the Analysis Probe. The Emulation Interface Software allows you to obtain displays of the microprocessor operations in SH7708 mnemonics or C-source.

For additional information on the supported logic analyzers or microprocessors, refer to the appropriate reference manuals for those products.

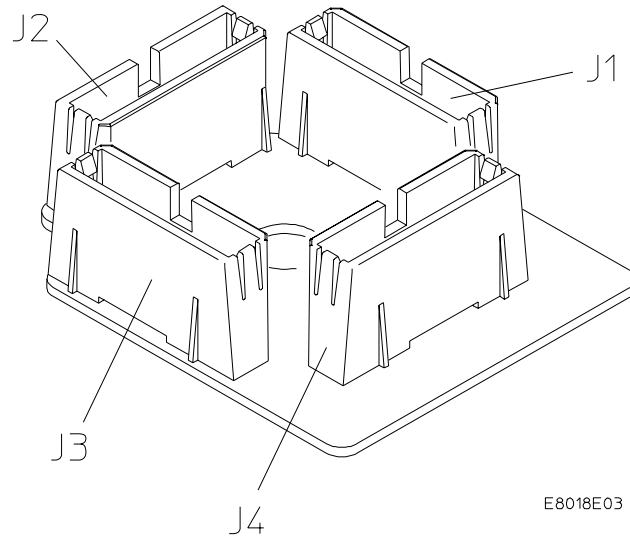

HP E8018A Analysis Probe

---

## In This Book

This book is the installation guide for the HP E8018A Analysis Probe . It assumes that you have a working knowledge of the logic analyzer used and the microprocessor being analyzed.

This installation guide is organized into three chapters:

Chapter 1 explains how to attach the Analysis Probe to the target and how to configure the logic analyzer for state and/or timing analysis.

Chapter 2 provides reference information on the format specification and symbols configured by the Analysis Probe software and information about the inverse assemblers and status encoding.

Chapter 3 contains reference information on the Analysis Probe hardware, including the characteristics and signal mapping for the Analysis Probe .

For more information on the logic analyzers or microprocessor, refer to the appropriate reference manual for those products.

## Contents

### **1 Installing Software**

To install the software from CD-ROM (HP 16600A/700A) 1-4

To list software packages which are installed (HP 16600A/700A) 1-5

### **2 Setting Up the Analysis Probe**

Before You Begin 2-3

Setting Up the Analysis Probe Hardware 2-5

Turn off the logic analyzer and the target system 2-5

To connect the Analysis Probe to the target system 2-6

To disconnect the Analysis Probe from the target system 2-7

To separate the Analysis Probe upper assembly from the probe head 2-8

To reconnect Analysis Probe and probe head 2-8

To connect the high-density adapter cables to the Analysis Probe 2-9

Setting up the Logic Analyzer 2-10

Connection Type 'A'

To connect to the HP 16600/1/2A analyzer 2-11

Connection Type 'B'

To connect to the HP 16550A one-card analyzer 2-12

Connection Type 'C'

To connect to the HP 16555/56/57A two-cards analyzer 2-13

Connection Type 'D'

To connect to the HP 16600/1A analyzer 2-14

Connection Type 'E'

To connect to the HP 16550A two-cards analyzer 2-15

Connection Type 'F'

To connect to the HP 16555/56/57A two-cards analyzer 2-16

Connection Type 'G'

To connect to the HP 16600A analyzer 2-17

## Contents

Connection Type 'H'  
To connect to the HP 16550A two-cards analyzer 2-18  
Connection Type 'I'  
To connect to the HP 16555/56/57A three-cards analyzer 2-19

Setup Assistant 2-20

### **3 Analysis Probe Hardware Reference**

Operating Characteristics 3-3  
Signal-to-Connector Mapping 3-3  
Circuit Board Dimensions 3-8  
Repair Strategy 3-9

### **A If You Have a Problem**

**Analyzer Problems A-3**

Intermittent data errors A-3  
Unwanted triggers A-3  
No activity on activity indicators A-4  
No trace list display A-4

**Analysis Probe Problems A-5**

Target system will not boot up A-5  
Erratic trace measurements A-6  
Capacitive loading A-6

**Intermodule Measurement Problems A-7**

An event wasn't captured by one of the modules A-7

**Messages A-8**

"Measurement Initialization Error" A-9  
"No Configuration File Loaded" A-10  
"Selected File is Incompatible" A-10  
"Slow or Missing Clock" A-10  
"Time from Arm Greater Than 41.93 ms" A-11  
"Waiting for Trigger" A-11

**Cleaning the Instrument A-12**

---

## Installing Software

---

# Installing Software

This chapter explains how to install the software you will need for your analysis probe or emulation solution.

## Installing and loading

**Installing** the software will copy the files to the hard disk of your logic analysis system. Later, you will need to **load** some of the files into the appropriate measurement module.

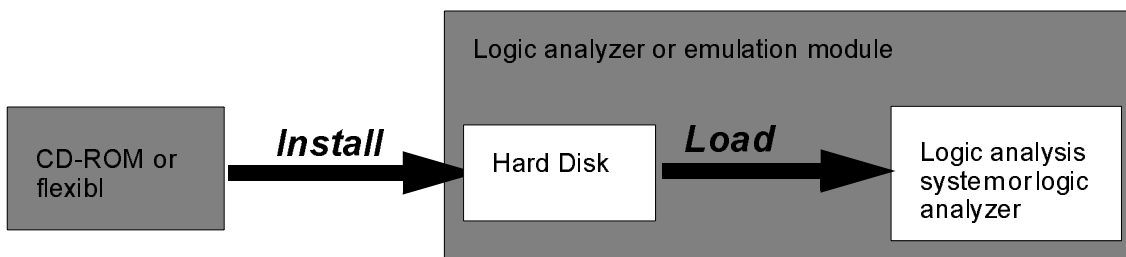



## **What needs to be installed**

### **HP 16600A/700A-series logic analysis systems**

If you ordered an analysis probe or emulation solution with your logic analysis system, the software was installed at the factory.

The following files are installed when you install a processor support package from the CD-ROM:

- Logic analysis system configuration files
- Personality files for the Setup Assistant

## To install the software from CD-ROM (HP 16600A/700A)

Installing a processor support package from a CD-ROM will take just a few minutes. If the processor support package requires an update to the HP 16600A/700A operating system, installation may take approximately 15 minutes.

**1 Insert the CD-ROM in the drive.**

**2 Click the System Admin icon.**

**3 Click Install... .**

Change the media type to "CD-ROM" if necessary.

**4 Click Apply.**

**5 From the list of types of packages, select "PROC-SUPPORT."**

A list of the processor support packages on the CD-ROM will be displayed.

**6 Click on the "SH3" package.**

If you are unsure if this is the correct package, click Details for information on what the package contains.

**7 Click Install... .**

The dialog box will display "Progress: completed successfully" when the installation is complete.

**8 Click Close.**

---

## To list software packages which are installed (HP 16600A/700A)

- In the System Administration Tools window, click **List...** .

Installing Software

**To list software packages which are installed (HP 16600A/700A)**

---

Installation Guide for HP E801A

---

## Installation Guide for HP E8018A

This chapter explains how to set up the HP E8018A Analysis Probe hardware, and connect the Analysis Probe to supported logic analyzers.

---

## Before You Begin

This section lists the logic analyzer(s) supported by the HP E8018A and provides other information about the analyzer(s) and the Analysis Probe .

### **Equipment Supplied**

- The HP E8018A SH7708 Analysis Probe , which includes the HP QFP Elastomeric Probing System
- Three HP E5346A High-Density Adapter Cables, and labels.
- A Cam Tool, for separating the Analysis Probe from the probing system.
- This Installation Guide.
- The HP QFP Elastomeric Probing System Installation Guide.

### **Minimum Equipment Required**

- The HP E8018A SH7708 Analysis Probe , including the HP QFP Elastomeric Probing System.
- Three HP E5346A High-Density Adapter Cables.
- One of the logic analyzers listed in the table on the following page.

Setting Up the Analysis Probe  
**Before You Begin**

---

**Logic Analyzers Supported**

---

<b>Logic Analyzer</b>	<b>Channel Count</b>	<b>State Speed</b>	<b>Timing Speed</b>	<b>Memory Depth</b>
16602A	102	100 MHz	125 MHz	64 k states
16601A	136	100 MHz	125 MHz	64 k states
16600A	208	100 MHz	125 MHz	64 k states
16550A (one cards)	102	100 MHz	250 MHz	4 k states
16550A (two cards)	204	100 MHz	250 MHz	4 k states
16555A (two cards)	136	110 MHz	250 MHz	1 M states
16555A (three cards)	204	110 MHz	250 MHz	1 M states
16555D (two cards)	136	110 MHz	250 MHz	2 M states
16555D (three cards)	204	110 MHz	250 MHz	2 M states
16556A (two cards)	136	100 MHz	200 MHz	1M states
16556A (three cards)	204	100 MHz	200 MHz	1M states
16556D (two cards)	136	100 MHz	200 MHz	2 M states
16556D (three cards)	204	100 MHz	200 MHz	2 M states
16557D (two cards)	136	135 MHz	500 MHz	4 M states
16557D (three cards)	204	135 MHz	500 MHz	4 M states



## Setting Up the Analysis Probe Hardware

Setting up the Analysis Probe hardware consists of the following major steps:

- Turn off the logic analyzer and the target system.
- Connect the Elastomeric Probing System retainer to the target system.
- Attach the Analysis Probe circuit board and adapter to the retainer.
- Attach the labels to the HP E5346A High-Density cables, then connect the cables to the Analysis Probe .
- Connect the logic analyzer pods to the high-density adapter cables.

The remainder of this section describes these general steps in more detail.

---

### Turn off the logic analyzer and the target system

To protect your equipment, remove the power from both the logic analyzer and the target system before you make or break connections. The logic analyzer should always be powered up before the target system. When powering down, power down the target system first and then power down the logic analyzer.

## To connect the Analysis Probe to the target system

Use the following steps to connect the Analysis Probe to the target system.

---

**CAUTION**

**Equipment Damage.** To prevent equipment damage, be sure to remove power from both the target system and the logic analyzer whenever the Analysis Probe is being connected or disconnected.

- 1 Turn off the target system and logic analyzer.**
- 2 Using the instructions in the *HP QFP Elastomeric Probing System Installation Guide*:**
  - Prepare to attach the Retainer to the QFP microprocessor
  - Test the alignment before adhering the Retainer
  - Adhere the Retainer to the QFP microprocessor
  - Install the HP E8018A Analysis Probe as described in "Install the Probe Adapter"
- 3 Using the illustration on the next page, note the following indicators:**
  - position of Pin 1 on the microprocessor
  - position of little pin on the retainer
  - position of little hole on the probe adapter

---

**CAUTION**

Serious damage to the target system or Analysis Probe can result from incorrect connection. Note the position of pin 1 on the target system and Analysis Probe prior to making any connection. Also, take care to align the pins so that all pins are making contact.

---

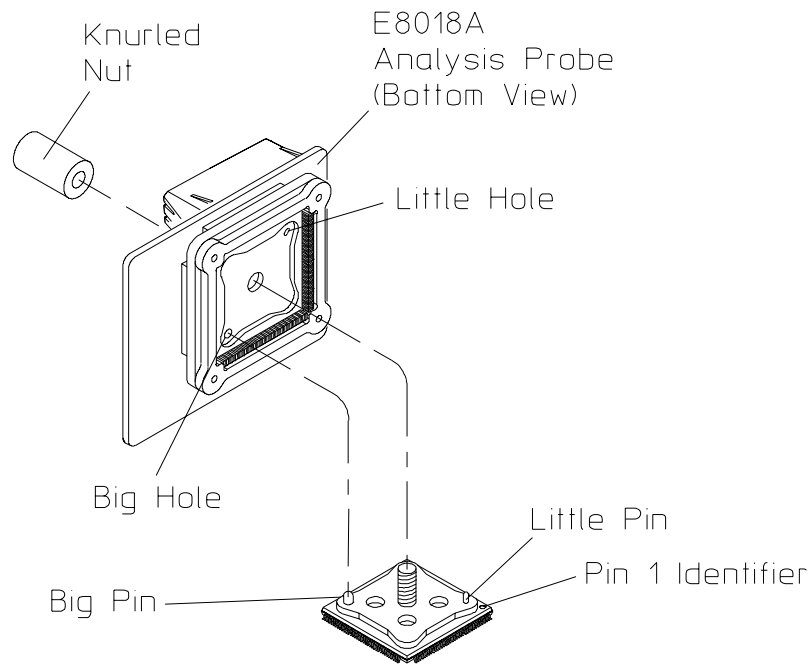

**Pin 1 Alignment for Target System and Analysis Probe**

---

## To disconnect the Analysis Probe from the target system

Use the following steps to disconnect the Analysis Probe from the target system.

- 1 Remove power from the target system.**
- 2 Remove power from the logic analyzer.**
- 3 Unscrew the knurled nut.**
- 4 Lift the Analysis Probe straight up.**

---

## To separate the Analysis Probe upper assembly from the probe head

Hewlett-Packard does not recommend separating the Analysis Probe upper assembly from the elastomeric probe head. However, unforeseen circumstances might require you to separate the assembly.

Use the Cam Tool supplied. Insert the tool into the first side as shown in the following illustration, and rotate it until the connectors begin to separate. Repeat this process for the other three sides in consecutive order until the Analysis Probe upper assembly and the elastomeric probe head are separated.

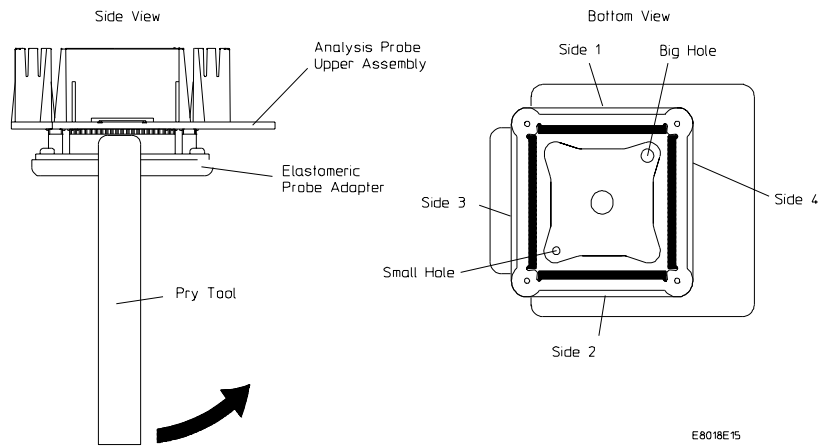

---

## To reconnect Analysis Probe and probe head

Place the elastomeric probe head in its protective cover. Orient the elastomeric probe head and the Analysis Probe upper assembly as shown in the illustration on the previous page. As you begin to insert the pins of the Analysis Probe upper assembly into the sockets on the elastomeric probe head, ensure that all of the pins are engaging. Look closely at both ends of all four sockets to ensure all pins are properly mated. Gently apply pressure until the connectors are fully mated.

---

## To connect the high-density adapter cables to the Analysis Probe

The high-density adapter cables, and labels to identify them, are included with the HP E8018A Analysis Probe. The labels identify the cables by the pod number, and "o" or "e" (for odd or even). Attach the labels to the cables, then connect the cables to the connectors on the Analysis Probe as shown in the following illustrations.

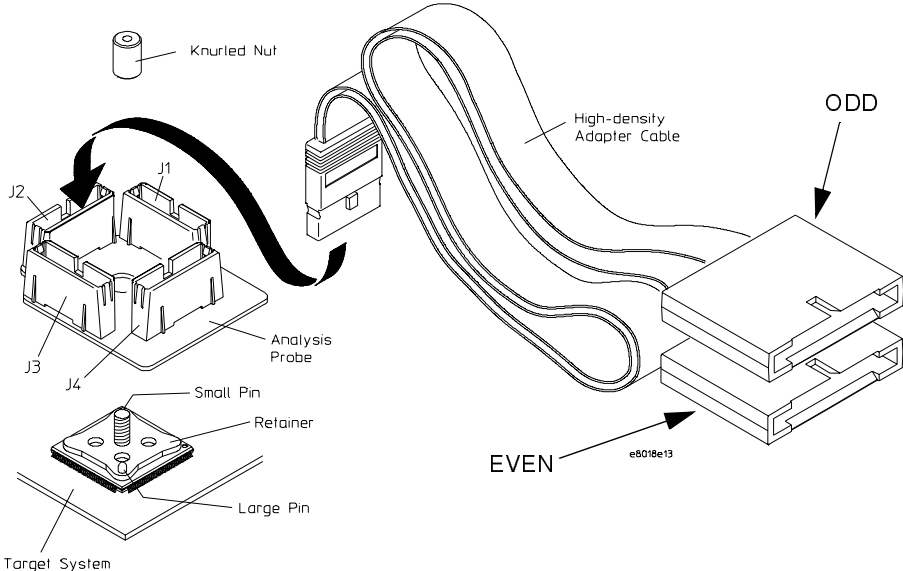

### High-Density Adapter Cables

## Setting up the Logic Analyzer

Connect the logic analyzer pod cables to the logic analyzer and to the mictor connector on the Analysis Probe . Required number of pods is depending on what memory you are using, how many wait cycles are interleaved, and speed of your target system's CKIO speed. See table below, then refer to the pod diagram for the analyzer you are using..

External Bus Speed	Memory Types Combination			Description	PODs	Minimum Logic Analyser supported	Config File	Connec- tion Type
	Other	EDO	SDRAM					
<=40MHz (*1)(*2)	D.C.	D.C.	D.C.	Any memory combina- tions with external bus speed of 40MHz or slower	6	16602A	SH7708F_0	A
						16700+16550A	SH7708F_0	B
						16700+16555/6/7x2(*2)	SH7708M_0	C
> 40MHz (*2)	YES	NO	NO	Any types of memory other than EDO-DRAM or SDRAM	6	16602A	SH7708F_1	A
						16700+16550A	SH7708F_1	B
						16700+16555/6/7x2(*2)	SH7708M_1	C
	D.C.	YES	NO	EDO-DRAM with any types of memory	8	16601A	SH7708F_2	D
						16700+16550Ax2	SH7708F_2	E
						16700+16555/6/7x2(*2)	SH7708M_2	F
	YES (w/wait)	NO	YES	SDRAM with other RAM with wait cycle	8	16601A	SH7708F_3	D
						16700+16550Ax2	SH7708F_3	E
						16700+16555/6/7x2(*2)	SH7708M_3	F
	YES (no-wait)	NO	YES	SDRAM with other RAM with no-wait cycle	10	16600A	SH7708F_4	G
						16700+16550Ax2	SH7708F_4	H
						16700+16555/6/7x3(*2)	SH7708M_4	I

D.C. = Don't Care

(\*1) Condition of <=40MHz : CKIO(cycle) = min25ns, CKIO(low)=min10ns, CKIO(high)=min10ns

(\*2) You may use any memory combinations under the bus speed of 50MHz using 16557.

Condition of <=50MHz : CKIO(cycle) = min20ns, CKIO(low)=min7.5ns, CKIO(high)=min7.5ns

### Note

If your 16700A Logic Analyzer equips with three card analyzer (One master, and two slave modules) and your connection type is either "C" or "F", you must detach one of the slave module on your logic analyzer. (One master, and one slave) Refer to the analyzer manual for the instruction on how to detach the module.

## Connection Type 'A' To connect to the HP 16600/1/2A analyzer

Connect the pod cables to the Analysis Probe according to the pod diagram below  
(continued on next page).

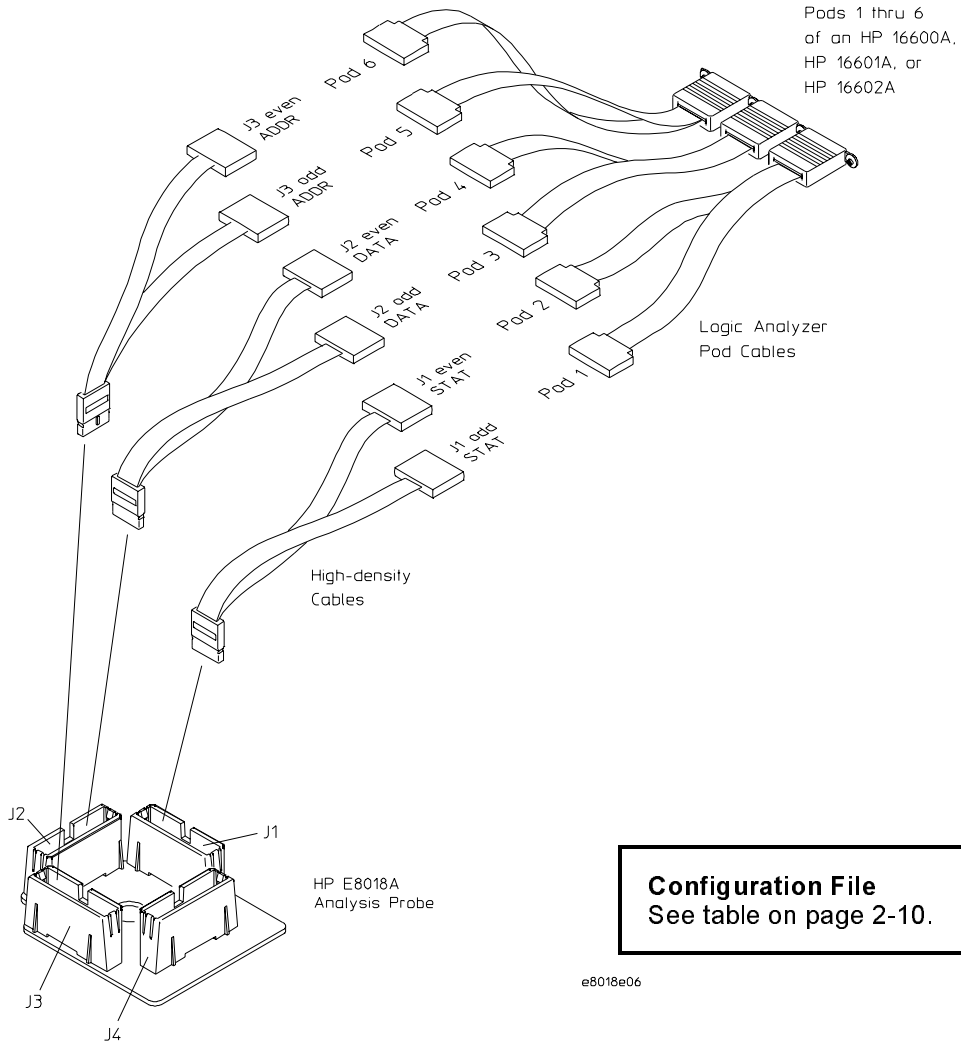

---

## Connection Type 'B' To connect to the HP 16550A one-card analyzer

Connect the pod cables to the Analysis Probe according to the pod diagram below (continued on next page).

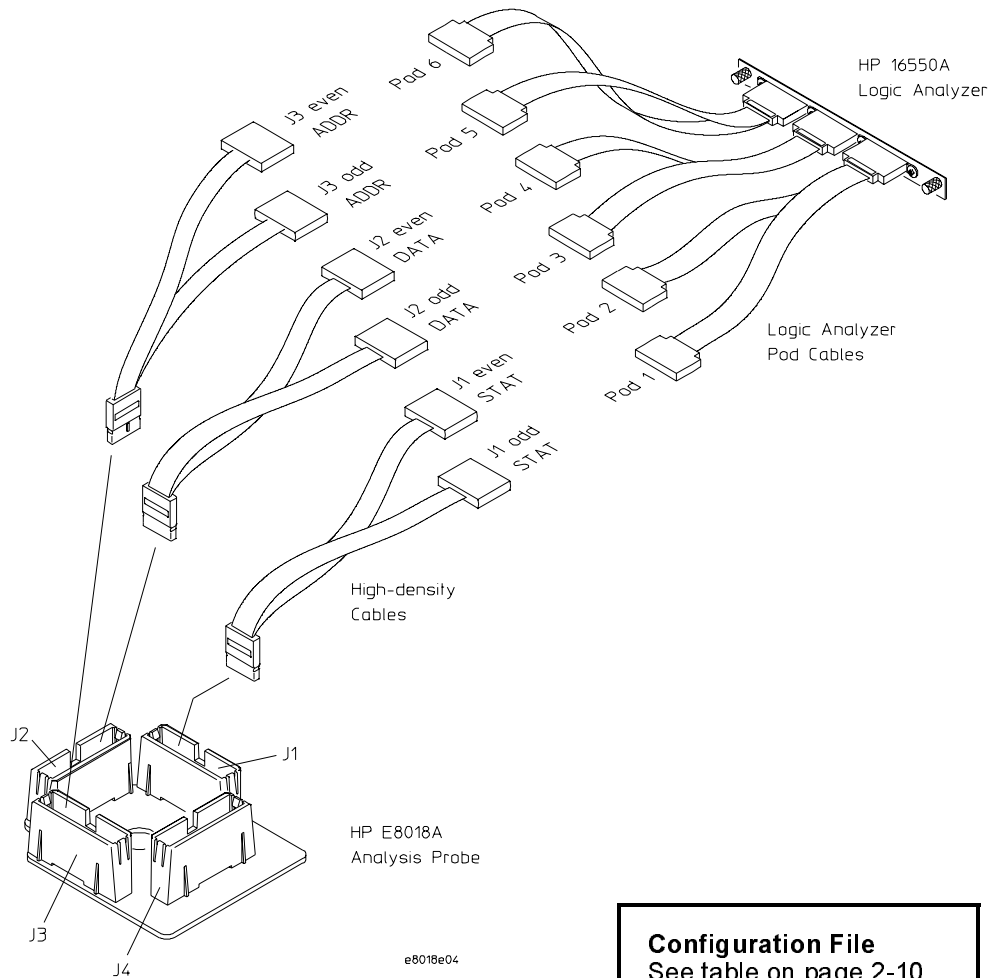

If your analyzer equips two cards of 16550A, connect all the cables above to "Master" module.



## Connection Type 'C' To connect to the HP 16555/56/57A two-cards analyzer

Connect the pod cables to the Analysis Probe according to the pod diagram below  
(continued on next page).

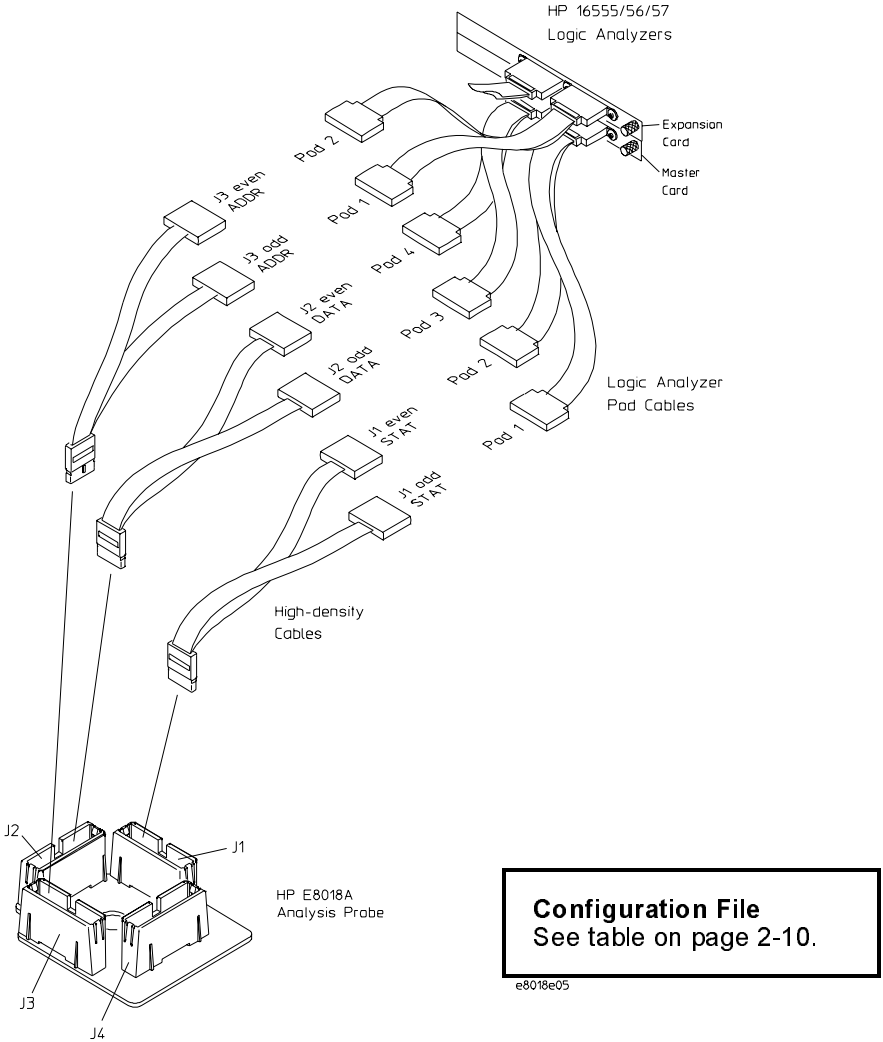

---

## Connection Type 'D' To connect to the HP 16600/1A analyzer

Connect the pod cables to the Analysis Probe according to the pod diagram below (continued on next page).

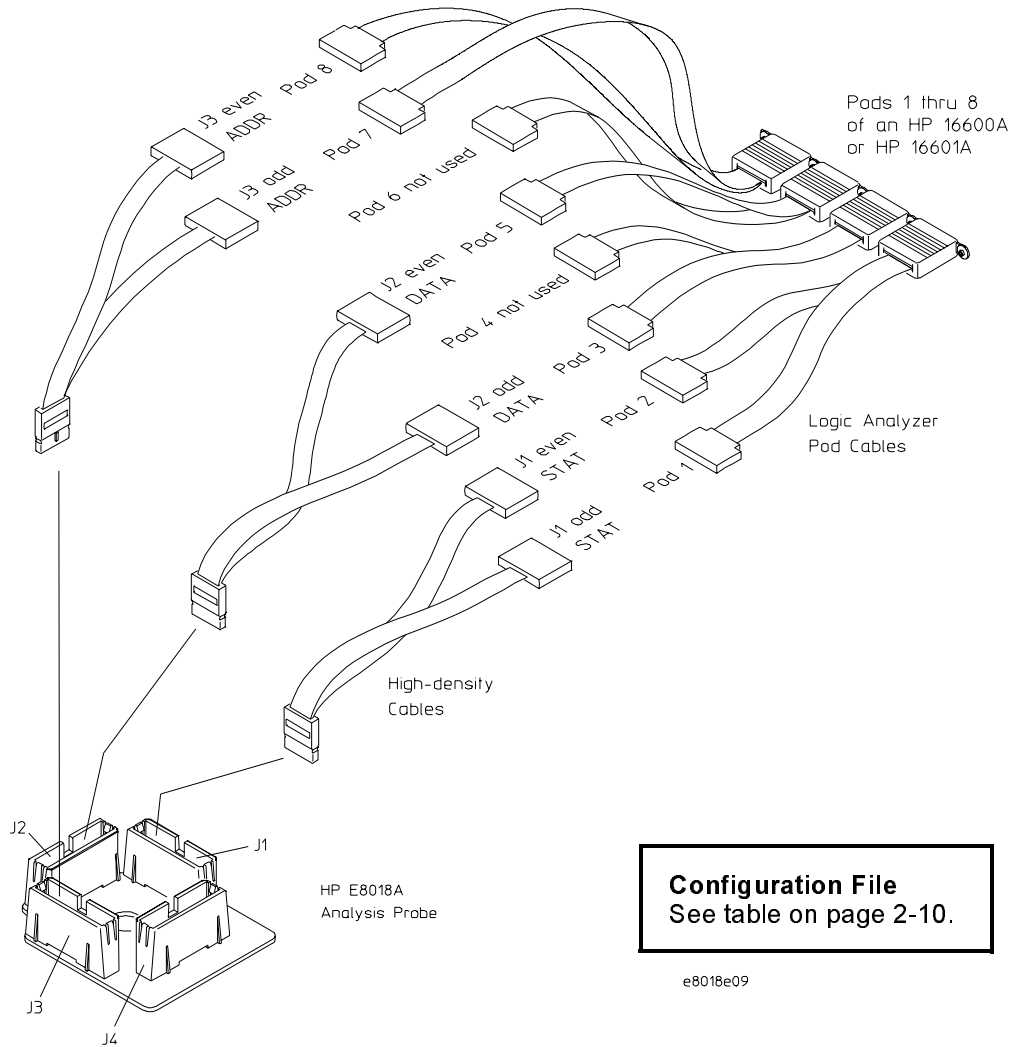

## Connection Type 'E' To connect to the HP 16550A two-cards analyzer

Connect the pod cables to the Analysis Probe according to the pod diagram below  
(continued on next page).

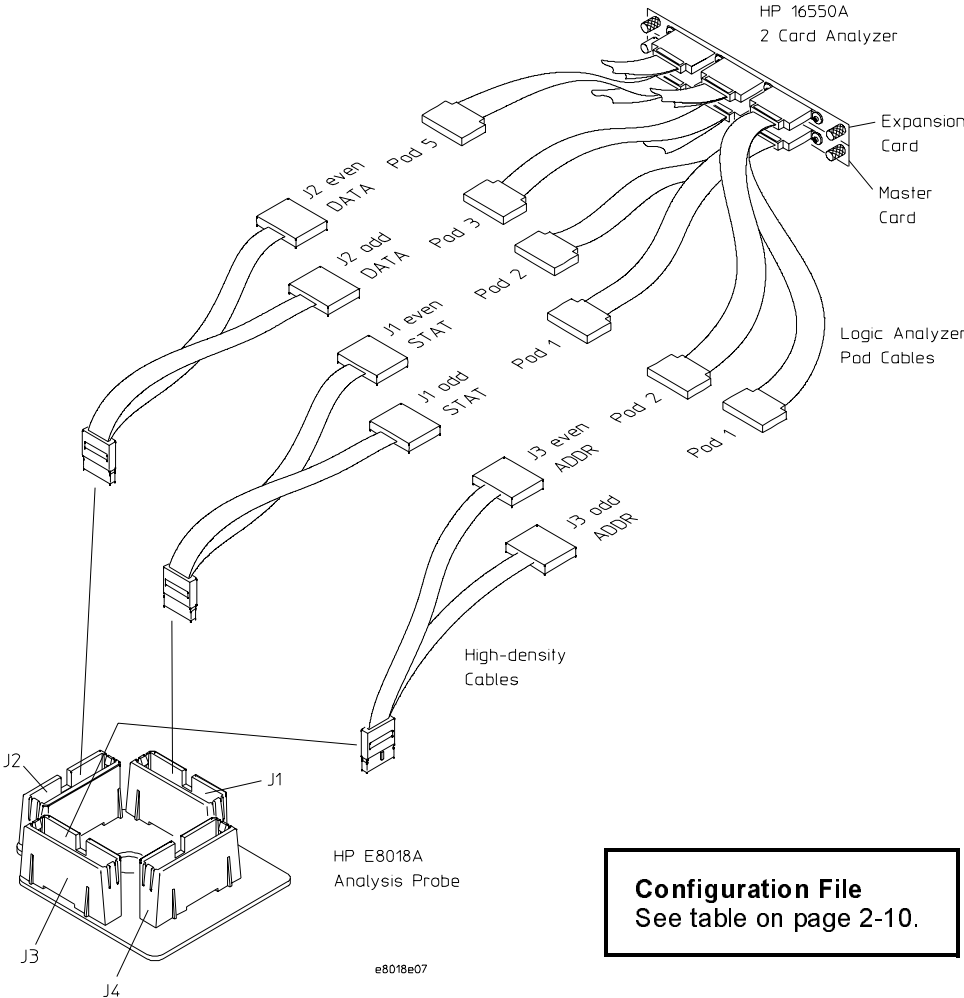

---

## Connection Type 'F' To connect to the HP 16555/56/57A two-cards analyzer

Connect the pod cables to the Analysis Probe according to the pod diagram below (continued on next page).

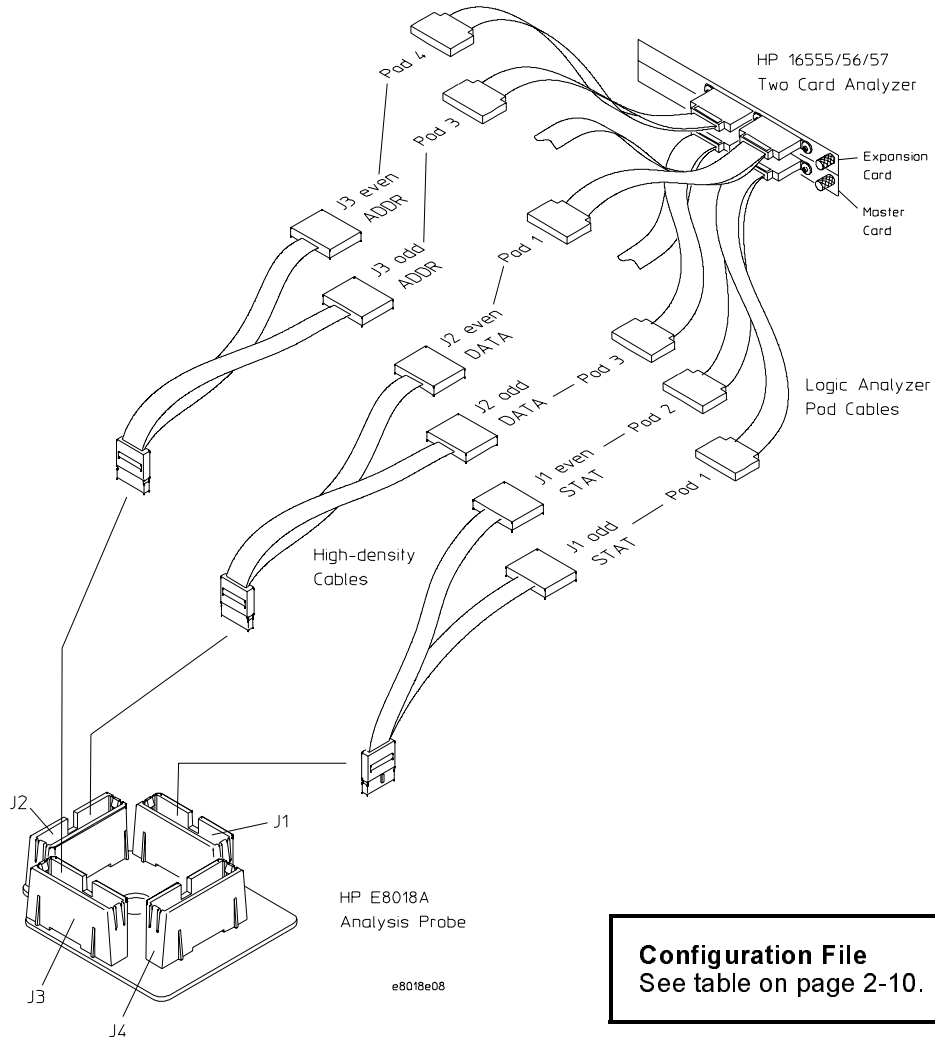

## Connection Type 'G' To connect to the HP 16600A analyzer

Connect the pod cables to the Analysis Probe according to the pod diagram below  
(continued on next page).

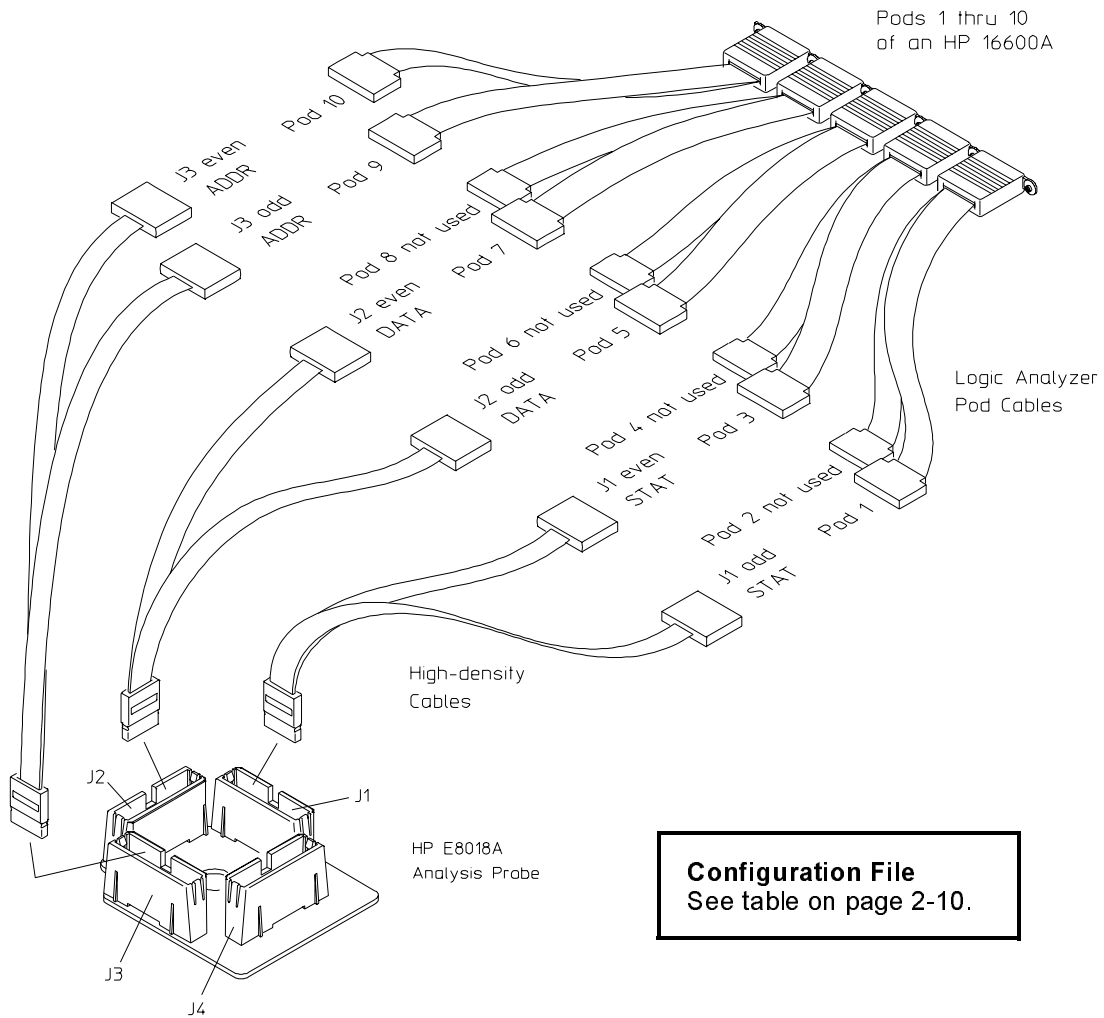

e8018e12

---

## Connection Type 'H' To connect to the HP 16550A two-cards analyzer

Connect the pod cables to the Analysis Probe according to the pod diagram below (continued on next page).

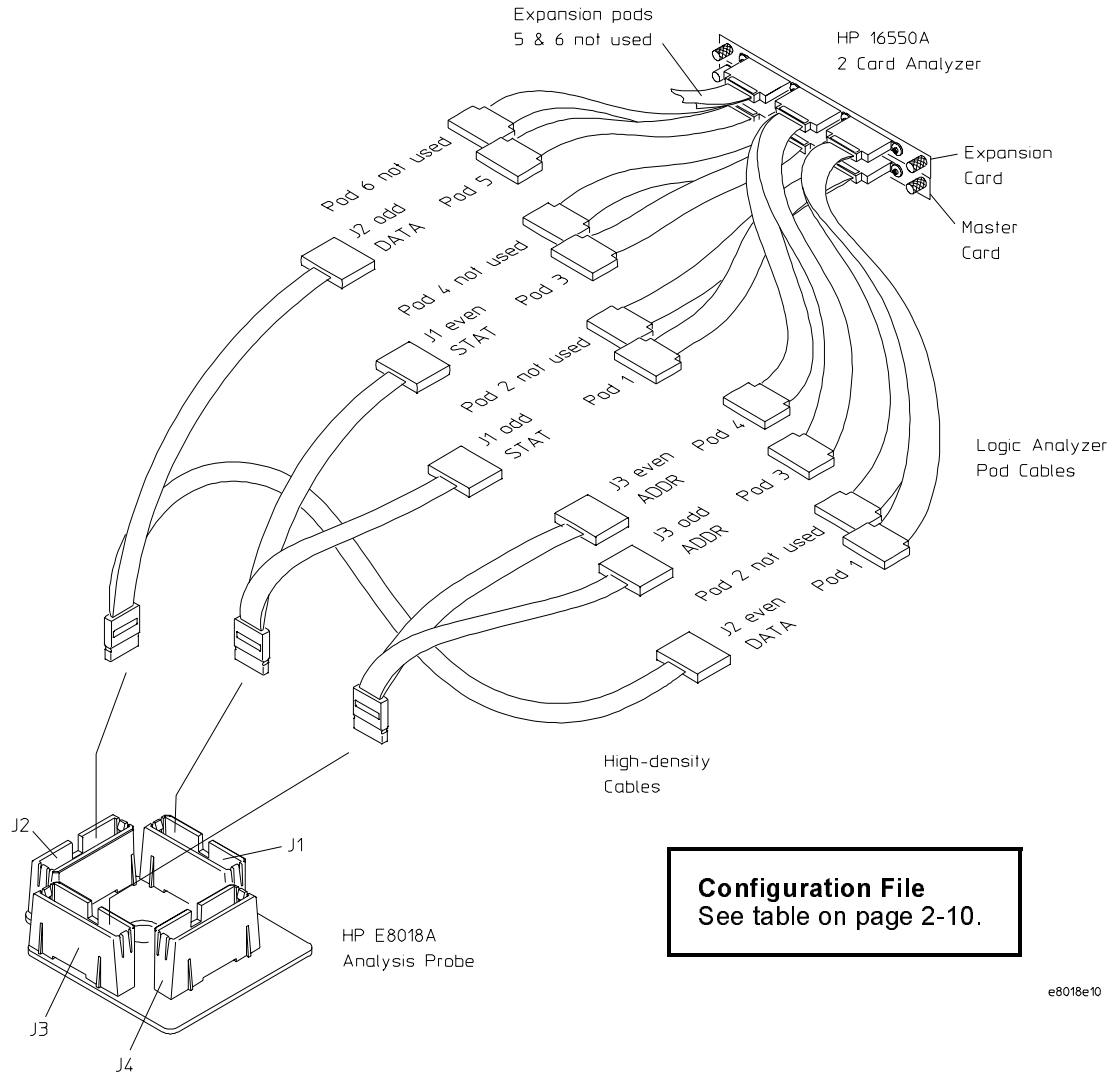

**Configuration File**  
See table on page 2-10.

e8018e10



---

## Setup Assistant

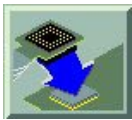

The Setup Assistant is an online tool for connecting and configuring your logic analysis system for microprocessor and bus analysis. The Setup Assistant is available on the HP 16600A and HP 16700A-series logic analysis systems. You can use the Setup Assistant in place of the connection and configuration procedures provided in this manual.

This menu-driven tool will guide you through the connection procedures for connecting the logic analyzer to an Analysis Probe, an emulation module, or other supported equipment. It will also guide you through connecting an Analysis Probe to the target system.

Start the Setup Assistant by clicking its icon in the system window.

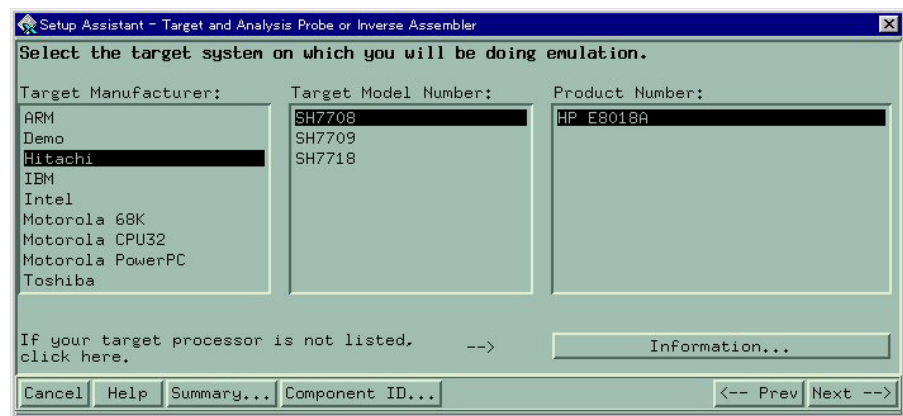

If you ordered this Analysis Probe or emulation solution with your HP 16600A/700A-series logic analysis system, the logic analysis system has the latest software installed, including support for this product. If you received this product after you received your logic analysis system, see the "Installing Software" chapter (page 1).



---

**CAUTION**

All operations must be done on the HP-B3759A( HP Emulation Interface Software ) except for the MSA.

After finishing MSA, don't touch anything on the state analysis listing window, although it pops up. Any changing on this window might cause a fatal error on a HP-B3759A( HP Emulation Interface Software ).

You can still operate other modules like analog scope. Also as long as you don't remove a state analysis machine, you can operate a workspace to perform cross domain measurement.

---

Setting Up the Analysis Probe  
**Setup Assistant**

---

n st a l i c i G u d e H P t u E 8 t u H  
0 H H H s A H

---

# Installation Guide

## HP E8018A SH7708/18 Analysis Probe

This chapter contains reference information on the HP E8018A hardware including product, electrical, and environmental characteristics, signal mapping, circuit board dimensions, and repair information.

---

## Operating Characteristics

The following operating characteristics are not specifications, but are typical operating characteristics for the Analysis Probe.

### Product Characteristics

Microcontroller Supported	Hitachi SH7708,7708S,7708R,7718
Package Supported	144-pin TQFP
Pods Required	6, 8, or 10 logic analyzer pods (three high-density adapter cables) are required for disassembly depending on your target system's memory. One high-density adapter cable is available for additional signal analysis.

### Electrical Characteristics

Power Requirements	None.
Signal Line Loading	10pF, 100 kohms on all signals.

### Environmental Characteristics

Temperature	Operating	0 to + 50 degrees C +32 to +131 degrees F
Altitude	Operating	4,600 m 15,000 feet
Humidity		Up to 75% noncondensing. Avoid sudden, extreme temperature changes which could cause condensation on the circuit board.

---

## Signal-to-Connector Mapping

The following table shows the the Analysis Probe PGA socket pin mapping.

Table 3-1

<b>SH7708 Signal List</b>					
<b>Connector</b>	<b>Analyzer Bit</b>	<b>SH7708 Pin #</b>	<b>Signal Name</b>	<b>Analyzer Label</b>	<b>Analyzer Label</b>
J1odd (6)	CLK1	131	CKE		
J1odd (8)	15	103	MD4/CE2B		
J1odd (10)	14	104	MD3/CE2A		
J1odd (12)	13	108	CS6/CE1B		
J1odd (14)	12	109	CS5/CE1A		
J1odd (16)	11	110	CS4		
J1odd (18)	10	111	CS3		
J1odd (20)	9	112	CS2		
J1odd (22)	8	113	CS1		
J1odd (24)	7	114	CS0		
J1odd (26)	6	106	RDWR		
J1odd (28)	5	117	WE3/DQMUU/ICIOR		
J1odd (30)	4	118	WE2/DQMUL/ICIOR		
J1odd (32)	3	123	WE1/DQMLU		
J1odd (34)	2	124	WE0/DQMLL		
J1odd (36)	1	107	RD		
J1odd (38)	0	105	BS		
J1even (5)	CLK1	101	CKIO		
J1even (7)	15	94	IOIS16		
J1even (9)	14	132	WAIT		
J1even (11)	13	87	BREQ		
J1even (13)	12	96	BACK		
J1even (15)	11	130	MD5/RAS2		
J1even (17)	10	129	RAS/CE		
J1even (19)	9	119	CASHH/CAS2H		
J1even (21)	8	120	CASHL/CAS2L		
J1even (23)	7	97	STATUS1		
J1even (25)	6	98	STATUS0		
J1even (27)	5	119	CASHH/CAS2H		
J1even (29)	4	120	CASHL/CAS2L		
J1even (31)	3	125	CASLH		
J1even (33)	2	126	CASLL/CAS/OE		
J1even (35)	1	130	MD5/RAS2		
J1even (37)	0	129	RAS/CE		

Connector	Analyzer Bit	SH7708 Pin #	Signal Name	Analyzer Label	Analyzer Label
J2odd (6)	CLK1				
J2odd (8)	15	15	D15		
J2odd (10)	14	16	D14		
J2odd (12)	13	21	D13		
J2odd (14)	12	22	D12		
J2odd (16)	11	23	D11		
J2odd (18)	10	24	D10		
J2odd (20)	9	25	D9		
J2odd (22)	8	26	D8		
J2odd (24)	7	27	D7		
J2odd (26)	6	28	D6		
J2odd (28)	5	29	D5		
J2odd (30)	4	32	D4		
J2odd (32)	3	33	D3		
J2odd (34)	2	34	D2		
J2odd (36)	1	35	D1		
J2odd (38)	0	36	D0		
J2even (5)	CLK1	88	RESET		
J2even (7)	15	140	D31		
J2even (9)	14	141	D30		
J2even (11)	13	142	D29		
J2even (13)	12	143	D28		
J2even (15)	11	1	D27		
J2even (17)	10	2	D26		
J2even (19)	9	3	D25		
J2even (21)	8	4	D24		
J2even (23)	7	5	D23/Port7		
J2even (25)	6	8	D22/Port6		
J2even (27)	5	9	D21/Port5		
J2even (29)	4	10	D20/Port4		
J2even (31)	3	11	D19/Port3		
J2even (33)	2	12	D18/Port2		
J2even (35)	1	13	D17/Port1		
J2even (37)	0	14	D16/Port0		

Analysis Probe Hardware Reference

Connector	Analyzer Bit	SH7708 Pin #	Signal Name	Analyzer Label	Analyzer Label
J3odd (6)	CLK1	95	IRQOUT		
J3odd (8)	15	58	A15		
J3odd (10)	14	57	A14		
J3odd (12)	13	56	A13		
J3odd (14)	12	53	A12		
J3odd (16)	11	52	A11		
J3odd (18)	10	51	A10		
J3odd (20)	9	48	A9		
J3odd (22)	8	47	A8		
J3odd (24)	7	46	A7		
J3odd (26)	6	45	A6		
J3odd (28)	5	44	A5		
J3odd (30)	4	43	A4		
J3odd (32)	3	40	A3		
J3odd (34)	2	39	A2		
J3odd (36)	1	38	A1		
J3odd (38)	0	37	A0		
J3even (5)	CLK1				
J3even (7)	15				
J3even (9)	14	90	IRL3		
J3even (11)	13	91	IRL2		
J3even (13)	12	92	IRL1		
J3even (15)	11	93	IRL0		
J3even (17)	10	89	NMI		
J3even (19)	9	72	A25		
J3even (21)	8	71	A24		
J3even (23)	7	70	A23		
J3even (25)	6	67	A22		
J3even (27)	5	66	A21		
J3even (29)	4	65	A20		
J3even (31)	3	64	A19		
J3even (33)	2	63	A18		
J3even (35)	1	62	A17		
J3even (37)	0	61	A16		



Connector	Analyzer Bit	SH7708 Pin #	Signal Name	Analyzer Label	Analyzer Label
J4odd (6)	CLK1	134	TCLK		
J4odd (8)	15				
J4odd (10)	14				
J4odd (12)	13				
J4odd (14)	12				
J4odd (16)	11				
J4odd (18)	10				
J4odd (20)	9				
J4odd (22)	8				
J4odd (24)	7				
J4odd (26)	6				
J4odd (28)	5				
J4odd (30)	4	84	MD2/RXD		
J4odd (32)	3	85	MD1/TXD		
J4odd (34)	2	86	MD0/SCK		
J4odd (36)	1	80	XTAL		
J4odd (38)	0	79	EXTAL		
J4even (5)	CLK1				
J4even (7)	15				
J4even (9)	14				
J4even (11)	13				
J4even (13)	12				
J4even (15)	11				
J4even (17)	10				
J4even (19)	9				
J4even (21)	8				
J4even (23)	7				
J4even (25)	6				
J4even (27)	5				
J4even (29)	4				
J4even (31)	3				
J4even (33)	2				
J4even (35)	1				
J4even (37)	0				

---

## Circuit Board Dimensions

The following figure gives the dimensions for the Analysis Probe assembly. The dimensions are listed in inches and millimeters.

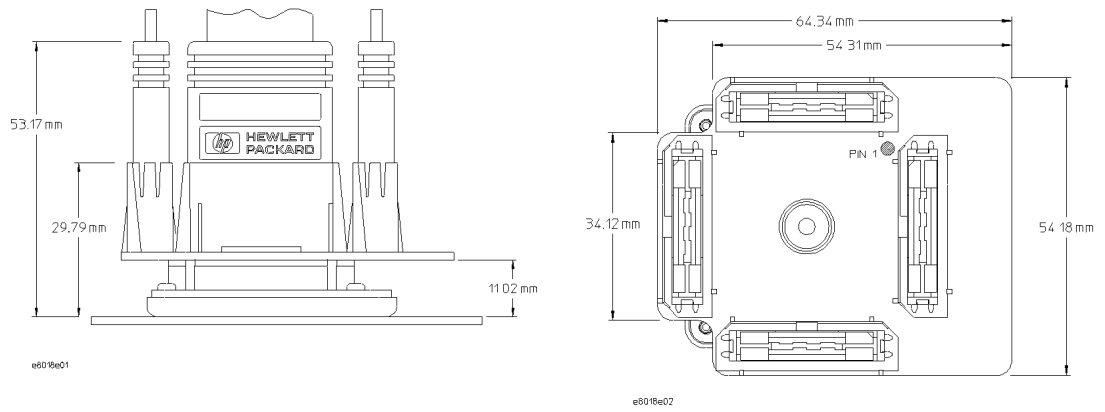

Circuit Board Dimension Diagram

---

## Repair Strategy

The repair strategy for this Analysis Probe is board replacement. However, the following table lists some mechanical parts that may be replaced if they are damaged or lost. Contact your nearest Hewlett-Packard Sales Office for further information on servicing the board.

Exchange assemblies are available when a repairable assembly is returned to Hewlett-Packard. These assemblies have been set up on the "Exchange Assembly" program. This allows you to exchange a faulty assembly with one that has been repaired, calibrated, and performance verified by the factory. The cost is significantly less than that of a new assembly.

**Table 3-2**

---

### Replaceable Parts

<b>HP Part Number</b>	<b>Description</b>
E5336A #201	Retainer Kit
E5336A #202	Locator Tool
E5350-23801	Cam Tool
E5336A	Adapter, Elastomeric, 144-pin QFP
E5346A	High-density Adapter Cable



---

Insta l i to Gut tdel H u E

---

## Installation Guide

Occasionally, a measurement may not give the expected results. If you encounter difficulties while making measurements, use this chapter to guide you through some possible solutions. Each heading lists a problem you may encounter, along with some possible solutions.

If you still have difficulty using the analyzer after trying the suggestions in this chapter, please contact your local Hewlett-Packard service center.

---

**CAUTION**

When you are working with the analyzer, be sure to power down both the analyzer and the target system before disconnecting or connecting cables, probes, and Analysis Probe. Otherwise, you may damage circuitry in the analyzer, Analysis Probe, or target system.

---

---

## Analyzer Problems

This section lists general problems that you might encounter while using the analyzer.

---

### Intermittent data errors

This problem is usually caused by poor connections, incorrect signal levels, or marginal timing.

- ❑ **Remove and reseat all cables and probes, ensuring that there are no bent pins on the Analysis Probe or poor probe connections.**
- ❑ **Adjust the threshold level of the data pod to match the logic levels in the system under test.**
- ❑ **Use an oscilloscope to check the signal integrity of the data lines.**

Clock signals for the state analyzer must meet particular pulse shape and timing requirements. Data inputs for the analyzer must meet pulse shape and setup and hold time requirements.

#### See Also

See "Capacitive Loading" in this chapter for information on other sources of intermittent data errors.

---

### Unwanted triggers

Unwanted triggers can be caused by instructions that were fetched but not executed.

- ❑ **Add the prefetch queue or pipeline depth to the trigger address to avoid this problem.**

The logic analyzer captures prefetches, even if they are not executed. When you are specifying a trigger condition or a storage qualification that follows an instruction that may cause branching, an unused prefetch may generate an unwanted trigger.

---

## No activity on activity indicators

- Check for loose cables, board connections, and Analysis Probe connections.**
- Check for bent or damaged pins on the Analysis Probe.**

---

## No trace list display

If there is no trace list display, it may be that your trigger specification is not correct for the data you want to capture, or that the trace memory is only partially filled.

- Check your trigger sequencer specification to ensure that it will capture the events of interest.**
- Try stopping the analyzer; if the trace list is partially filled, this should display the contents of trace memory.**



---

## Analysis Probe Problems

This section lists problems that you might encounter when using a Analysis Probe. If the solutions suggested here do not correct the problem, you may have a damaged Analysis Probe. Contact your local Hewlett-Packard Sales Office if you need further assistance.

---

### Target system will not boot up

If the target system will not boot up after connecting the Analysis Probe , the microprocessor (if socketed) or the Analysis Probe may not be installed properly, or they may not be making electrical contact.

- Ensure that you are following the correct power-on sequence for the Logic Analyzer and target system.**

- 1 Power up the Logic Analyzer.
- 2 Power up the target system.

If you power up the target system before you power up the Logic Analyzer, interface circuitry in the Analysis Probe may latch up and prevent proper target system operation.

- Verify that the microprocessor and the Analysis Probe are properly rotated and aligned, so that the index pin on the microprocessor (pin A1) matches the index pin on the Analysis Probe .**
- Verify that the microprocessor and the Analysis Probe are securely inserted into their respective sockets.**
- Verify that the logic analyzer cables are in the proper sockets of the Analysis Probe and are firmly inserted.**

## Erratic trace measurements

There are several general problems that can cause erratic variations in trace lists and inverse assembly failures.

- ❑ **Do a full reset of the target system before beginning the measurement.**

Some Analysis Probe designs require a full reset to ensure correct configuration.

- ❑ **Ensure that your target system meets the timing requirements of the processor with the Analysis Probe installed.**

See "Capacitive Loading" in this chapter. While Analysis Probe loading is slight, pin protectors, extenders, and adapters may increase it to unacceptable levels. If the target system design has close timing margins, such loading may cause incorrect processor functioning and give erratic trace results.

- ❑ **Ensure that you have sufficient cooling for the microprocessor.**

Microprocessors such as the i486, Pentium?, and MC68040 generate substantial heat. This is exacerbated by the active circuitry on the preprocessor board. You should ensure that you have ambient temperature conditions and airflow that meet or exceed the requirements of the microprocessor manufacturer.

---

## Capacitive loading

Excessive capacitive loading can degrade signals, resulting in incorrect capture by the Analysis Probe, or system lockup in the microprocessor. All Analysis Probe s add additional capacitive loading, as can custom probe fixtures you design for your application.

Careful layout of your target system can minimize loading problems and result in better margins for your design. This is especially important for systems that are running at frequencies greater than 50 MHz.

- ❑ **Remove as many pin protectors, extenders, and adapters as possible.**
- ❑ **If multiple Analysis Probe solutions are available, use one with lower capacitive loading.**

---

## Intermodule Measurement Problems

Some problems occur only when you are trying to make a measurement involving multiple modules.

---

### An event wasn't captured by one of the modules

If you are trying to capture an event that occurs very shortly after the event that arms one of the measurement modules, it may be missed due to internal analyzer delays. For example, suppose you set the oscilloscope to trigger upon receiving a trigger signal from the logic analyzer because you are trying to capture a pulse that occurs right after the analyzer's trigger state. If the pulse occurs too soon after the analyzer's trigger state, the oscilloscope will miss the pulse.

**Adjust the skew in the Intermodule menu.**

You may be able to specify a skew value that enables the event to be captured.

**Change the trigger specification for modules upstream of the one with the problem.**

If you are using a logic analyzer to trigger the scope, try specifying a trigger state one state before the one you are using. This may be more difficult than working with the skew because the prior state may occur more often and not always be related to the event you are trying to capture with the oscilloscope.

---

## Messages

This section lists some of the messages that the analyzer displays when it encounters a problem.

---

## “Measurement Initialization Error”

This error occurs when you have installed the cables incorrectly for one or two HP 16550A logic analysis cards. The following diagrams show the correct cable connections for one-card and two-card installations. Ensure that your cable connections match the silk screening on the card, and that they are fully seated in the connectors. Then, repeat the measurement.

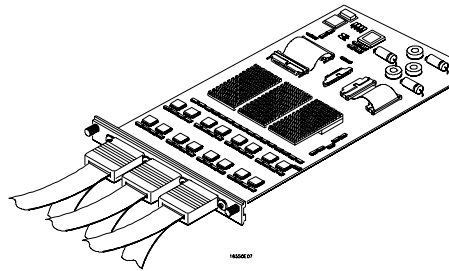

**Cable Connections for One-Card HP 16550A Installations**

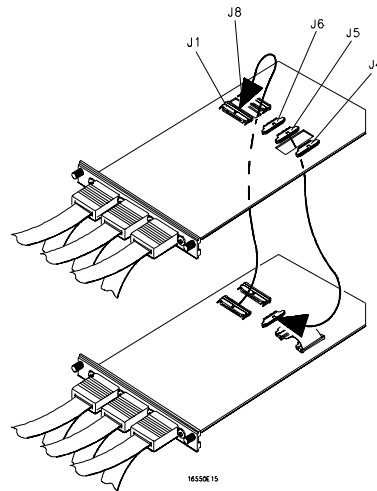

**Cable Connections for Two-Card HP 16550A Installations**

**See Also**

The *HP 16550A 100-MHz State/500-MHz Timing Logic Analyzer Service Guide*.

---

## “No Configuration File Loaded”

This is usually caused by trying to load a configuration file for one type of module/system into a different type of module/system.

- ❑ **Verify that the appropriate module has been selected from the Load {module} from File {filename} in the HP 16500A/B disk operation menu. Selecting Load {All} will cause incorrect operation when loading most Analysis Probe configuration files.**

### See Also

Chapter 1 describes how to load configuration files.

---

## “Selected File is Incompatible”

This occurs when you try to load a configuration file for the wrong module. Ensure that you are loading the appropriate configuration file for your logic analyzer.

---

## “Slow or Missing Clock”

- ❑ **This error message might occur if the logic analyzer cards are not firmly seated in the HP 16500A/B or HP 16501A frame. Ensure that the cards are firmly seated.**
- ❑ **This error might occur if the target system is not running properly. Ensure that the target system is on and operating properly.**
- ❑ **If the error message persists, check that the logic analyzer pods are connected to the proper connectors on the Analysis Probe . See Chapter 1 to determine the proper connections.**

---

## “Time from Arm Greater Than 41.93 ms”

The state/timing analyzers have a counter to keep track of the time from when an analyzer is armed to when it triggers. The width and clock rate of this counter allow it to count for up to 41.93 ms before it overflows. Once the counter has overflowed, the system does not have the data it needs to calculate the time between module triggers. The system must know this time to be able to display data from multiple modules on a single screen.

---

## “Waiting for Trigger”

If a trigger pattern is specified, this message indicates that the specified trigger pattern has not occurred. Verify that the triggering pattern is correctly set.

- ❑ **When analyzing microprocessors that fetch only from word-aligned addresses, if the trigger condition is set to look for an opcode fetch at an address not corresponding to a word boundary, the trigger will never be found.**

---

## Cleaning the Instrument

If this instrument requires cleaning, disconnect it from all power sources and clean it with a mild detergent and water. Make sure the instrument is completely dry before reconnecting it to a power source.



---

©Copyright Hewlett-Packard Company 1996  
All Rights Reserved.

Reproduction, adaptation, or translation without prior written permission is prohibited, except as allowed under the copyright laws.

#### Restricted Rights Legend

Use, duplication, or disclosure by the U.S. Government is subject to restrictions set forth in subparagraph (C) (1) (ii) of the Rights in Technical Data and Computer Software Clause in DFARS 252.227-7013.

Hewlett-Packard Company,  
3000 Hanover Street, Palo Alto, CA 94304 U.S.A.

Rights for non-DOD U.S. Government Departments and Agencies are set forth in FAR 52.227-19(e)(1,2).

#### Document Warranty

The information contained in this document is subject to change without notice.

**Hewlett-Packard makes no warranty of any kind with regard to this material, including, but not limited to, the implied warranties of merchantability or fitness for a particular purpose.**

Hewlett-Packard shall not be liable for errors contained herein or for damages in connection with the furnishing, performance, or use of this material.

#### Safety

This apparatus has been designed and tested in accordance with International Safety Requirements. To ensure safe operation and to keep the product safe, the information, cautions, and warnings in this user's guide must be heeded. In addition, note the external markings on the product that are described under "Safety Symbols."

#### Safety Symbols



Instruction manual symbol: the product is marked with this symbol when it is necessary for you to refer to the instruction manual in order to protect against damage to the product.



Hazardous voltage symbol.



Earth terminal symbol: Used to indicate a circuit common connected to grounded chassis.

#### WARNING

The Warning sign denotes a hazard. It calls attention to a procedure, practice, or the like, which, if not correctly performed or adhered to, could result in personal injury. Do not proceed beyond a Warning sign until the indicated conditions are fully understood and met.

#### CAUTION

The Caution sign denotes a hazard. It calls attention to an operating procedure, practice, or the like, which, if not correctly performed or adhered to, could result in damage to or destruction of part or all of the product. Do not proceed beyond a Caution symbol until the indicated conditions are fully understood or met.

### **Product Warranty**

This Hewlett-Packard product has a warranty against defects in material and workmanship for a period of one year from date of shipment. During the warranty period, Hewlett-Packard Company will, at its option, either repair or replace products that prove to be defective.

For warranty service or repair, this product must be returned to a service facility designated by Hewlett-Packard.

For products returned to Hewlett-Packard for warranty service, the Buyer shall prepay shipping charges to Hewlett-Packard and Hewlett-Packard shall pay shipping charges to return the product to the Buyer. However, the Buyer shall pay all shipping charges, duties, and taxes for products returned to Hewlett-Packard from another country.

Hewlett-Packard warrants that its software and firmware designated by Hewlett-Packard for use with an instrument will execute its programming instructions when properly installed on that instrument.

Hewlett-Packard does not warrant that the operation of the instrument software, or firmware will be uninterrupted or error free.

### **Limitation of Warranty**

The foregoing warranty shall not apply to defects resulting from improper or inadequate maintenance by the Buyer, Buyer-supplied software or interfacing, unauthorized modification or misuse, operation outside of the environmental specifications for the product, or improper site preparation or maintenance.

**No other warranty is expressed or implied. Hewlett-Packard specifically disclaims the implied warranties of merchantability or fitness for a particular purpose.**

### **Exclusive Remedies**

The remedies provided herein are the buyer's sole and exclusive remedies. Hewlett-Packard shall not be liable for any direct, indirect, special, incidental, or consequential damages, whether based on contract, tort, or any other legal theory.

### **Assistance**

Product maintenance agreements and other customer assistance agreements are available for Hewlett-Packard products.

For any assistance, contact your nearest Hewlett-Packard Sales Office.

### **Certification**

Hewlett-Packard Company certifies that this product met its published specifications at the time of shipment from the factory. Hewlett-Packard further certifies that its calibration measurements are traceable to the United States National Institute of Standards and Technology, to the extent allowed by the Institute's calibration facility, and to the calibration facilities of other International Standards Organization members.

### **About this edition**

This is the *HP E8018A SH7708/18 Analysis Probe User's Guide*.

Publication number  
E8018-97000  
Printed in USA.  
Edition dates are as follows:  
First edition, August 1998

Next editions are complete revisions of the manual. Update packages, which are issued between editions, contain additional and replacement pages to be merged into the manual by you. The dates on the title page change only when a new edition is published.

A software or firmware code may be printed before the date. This code indicates the version level of the software or firmware of this product at the time the manual or update was issued. Many product updates do not require manual changes; and, conversely, manual corrections may be done without accompanying product changes. Therefore, do not expect a one-to-one correspondence between product updates and manual updates.

The following list of pages gives the date of the current edition and of any changed pages to that edition.

All pages original edition